

Ruby  
**TRUE COMPACT RHYTHM**



**GAGGIA**

# GAGGIA RUBY

## TRUE COMPACT RHYTHM

Close your eyes. Listen to the first drumbeats. You know your favourite song is about to ring out. That is how **the flavour of the best coffee is expressed on the new Gaggia Ruby**, a machine specifically designed for Office Coffee Service (OCS) and **for coffee serving outlets without much space or with low coffee consumption.**

Like the all-enveloping sound of a set of drums, **Gaggia Ruby is a modern machine**, compact and powerful, offering top performance in a small size. **It is the machine for coffee enthusiasts who have limited space available, but who insist on offering the best coffee** like that of professional foodservice establishments.

**Gaggia Ruby is a high-quality, durable, compact and powerful espresso machine** which uses group heads, filter holders and solenoids found on professional machines.



TRUE COMPACT  
RHYTHM

# HIGH PERFORMANCE

## GAGGIA RUBY

### PRESSURE GAUGE

- High precision

### HOT WATER OUTLET

- For the preparation of teas

### FILTER HOLDERS

- Ergonomic
- Non-slip

### BOILER

- Water level electronically controlled

### DRIP TRAY

- Easily removed for cleaning, with “full” indicator in machines with inbuilt water tank

### VERSIONS

- Available in capsule-ready versions

### FILTER HOLDER KITS FOR DIFFERENT CAPSULE FORMATS (OPTIONAL)



### WATER TANK (According to model)

- Easy access to fill the water tank

### PUSHBUTTONS

- 2 programmable dose selections and continuous button for each group

### PROFESSIONAL GROUPS

- Same groups, filter holders and solenoids used on professional machines.

### FILTER HOLDERS

- Coffee outlet for cups up to 9.5 cm tall
- Narrow two cup filter holder for double or single coffee service

### STEAM ARM

- Rotational stainless steel outlet

### FEET

- Hard-wearing
- Non-slip

## THE FULL RANGE FEATURES

Designed to adapt to any need thanks to versions that use ground coffee, capsules or pods

- **RUBY OFFICE**  
For small offices or coffee break areas  
Incorporates exclusive “Espresso Priority System” to complete espresso preparation even if the tank reaches the minimum water level, or if the boiler needs to take on water after making tea or frothing milk
- **RUBY PRO**  
Ideal for offices or small canteens
- **RUBY PRO TWO**  
For outlets with greater coffee consumption. Prepare up to four cups of coffee at the same time

Models available with filter holders for different capsule formats  
**(Nespresso, Lavazza Blue, Espresso Point, Caffitaly, etc.)\***

- **INBUILT TANK VERSIONS**
  - Easy to fill water tank
  - Easy to remove drip tray with “full” indicator
  - No direct water connection needed

\*The registered brands ‘Nespresso®’, ‘Lavazza Blue®’, ‘Espresso Point®’ and ‘Caffitaly®’ are not property of Quality Espresso nor any group company.

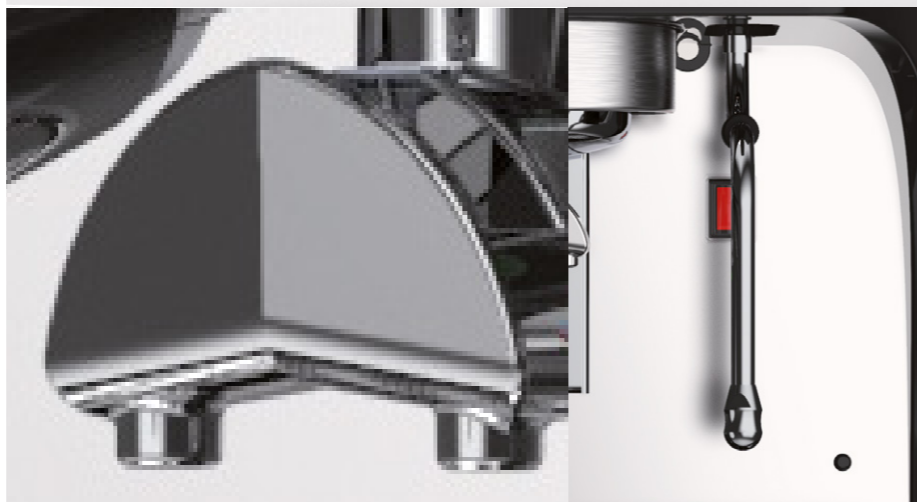

### TECHNICAL DATA

#### TECHNICAL FEATURES

Dimensions  
(Height x Width x Depth)

Weight

Colours

### RUBY OFFICE

1 GROUP

37 x 31 x 51 cm

18 Kg

1 ●

### RUBY PRO

1 GROUP

37 x 43 x 51 cm

25 Kg

3 ●●●

### RUBY PRO TWO

2 GROUPS

37 x 57 x 51 cm

33 Kg

3 ●●●

### OTHER TECHNICAL DATA

Voltage  
Models with rotary pump

Voltage  
Models with vibration pump(s)

Total absorbed power

Boiler capacity

Filter holders

Water connection

230V/50-60 Hz

230V/50 Hz

1640 W

1,5 l

1

- 3 litre inbuilt water tank  
with 1 vibration pump

230V/50-60 Hz

230V/50 Hz

2640 W

5 l

1

- 3 litre inbuilt water tank  
with 2 vibration pumps  
- Direct water connection  
with rotary pump

230V/50-60 Hz

230V/50 Hz

2640 W

6,5 l

2

- 5 litre inbuilt water tank  
with 3 vibration pumps  
- Direct water connection  
with rotary pump



**QUALITY ESPRESSO**

*Capture the Essence*

QUALITY ESPRESSO S.A.U.

Motores, 1-9, 08040 Barcelona, Spain

Tel: 93 223 12 00 - Export tel: +34 933 946 305 - [info@qualityespresso.net](mailto:info@qualityespresso.net)

[www.qualityespresso.net](http://www.qualityespresso.net)

Quality Espresso offers products certified by independent laboratories and backed by an experience of more than 60 years

The activities and systems of Quality Espresso comply with ISO 9001:15

In the interest of continuous product development, the manufacturer reserves the right to modify the characteristics of the appliances presented in this publication without notice